

West -4008

Figure 1

Take Off Original Visor & Grind Off Original Brackets From Truck. Grind The "Huck Bolt" To Take Brackets Off

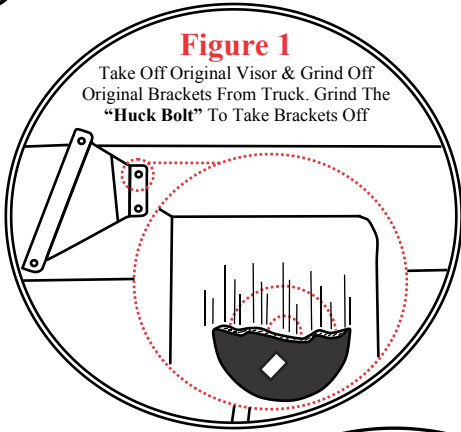

Figure 2

Put The Visor Together With The Brackets & Put The Side Screws On & Mark The Holes For The Brackets So You Can Drill Them Out To Put On Brackets.

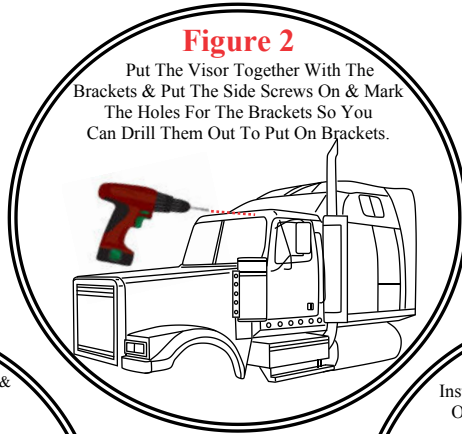

Figure 3

Put on New Brackets & Tighten Them On To The Truck

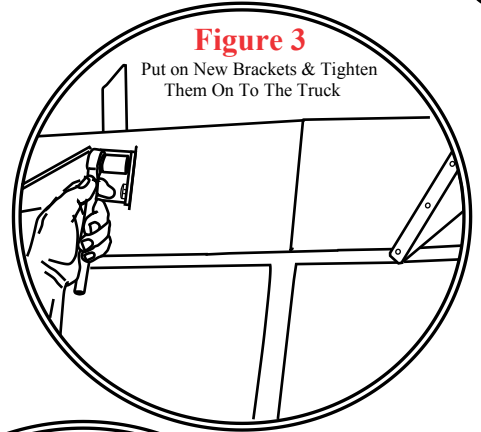

Figure 4

Now Place The Visor On Top Of Brackets & Tighten All The Screws

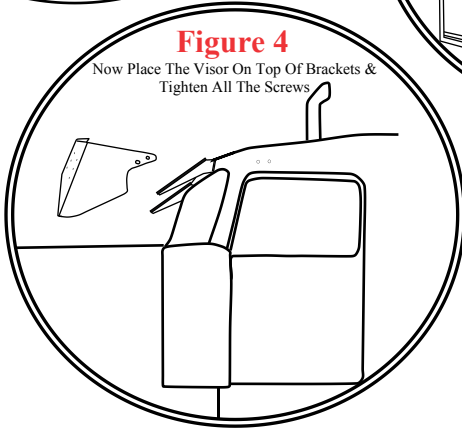
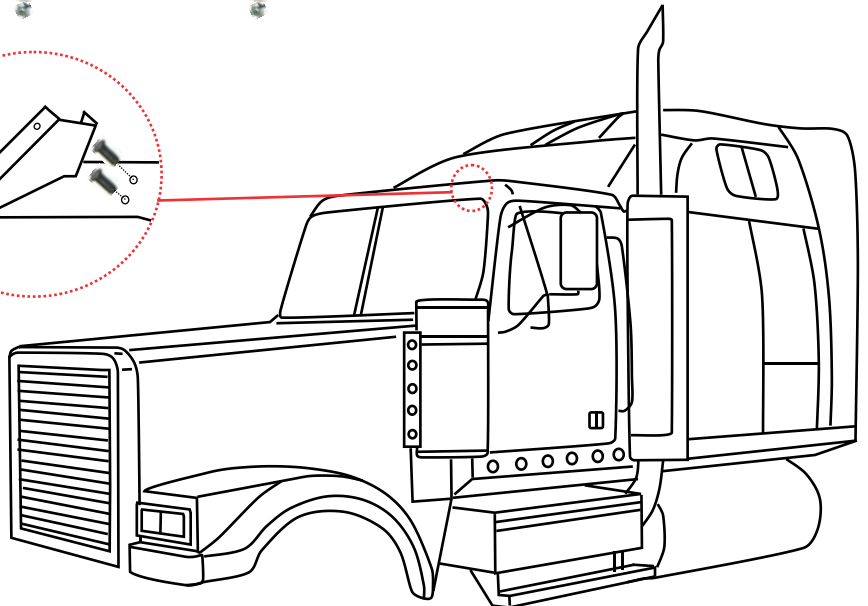
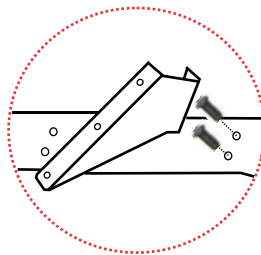
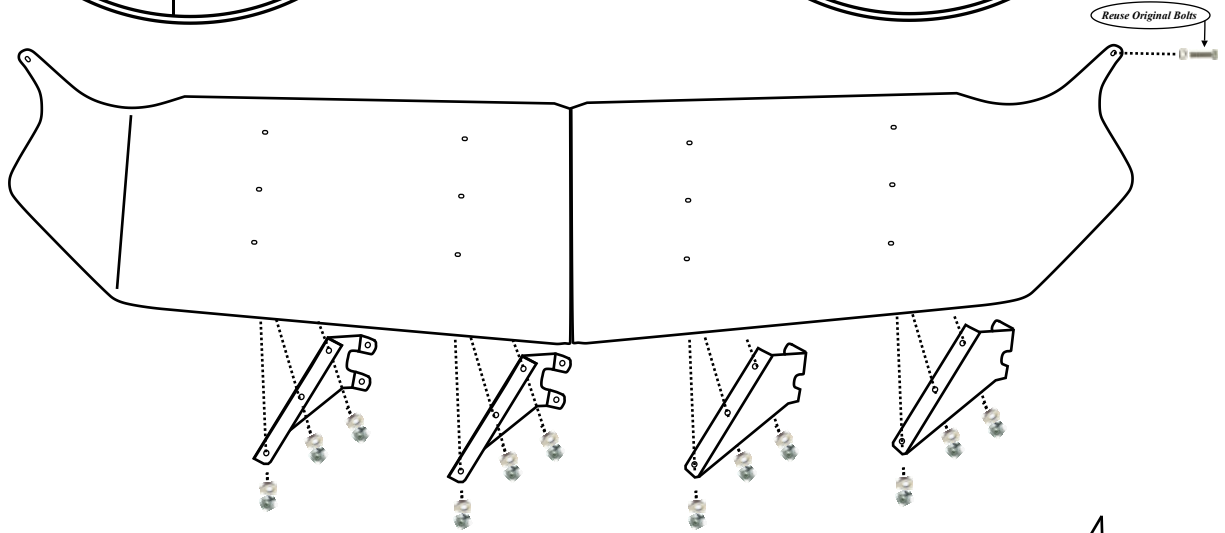
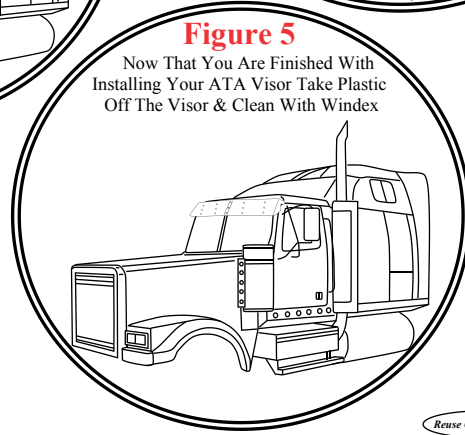

Figure 5

Now That You Are Finished With Installing Your ATA Visor Take Plastic Off The Visor & Clean With Windex



Bolt Kit

	QTY: 11	Pan Phillips	1/4 - 20 x 3/4
	QTY: 30	Flat Washer	1/4 x 5/8
	QTY: 8	Weld Nut	1/4 - 20 x 1"
	QTY: 8	Hex Head	1/4 - 20 x 1 1/4
	QTY: 11	Nylon Hex Nuts	1/4 x 20